

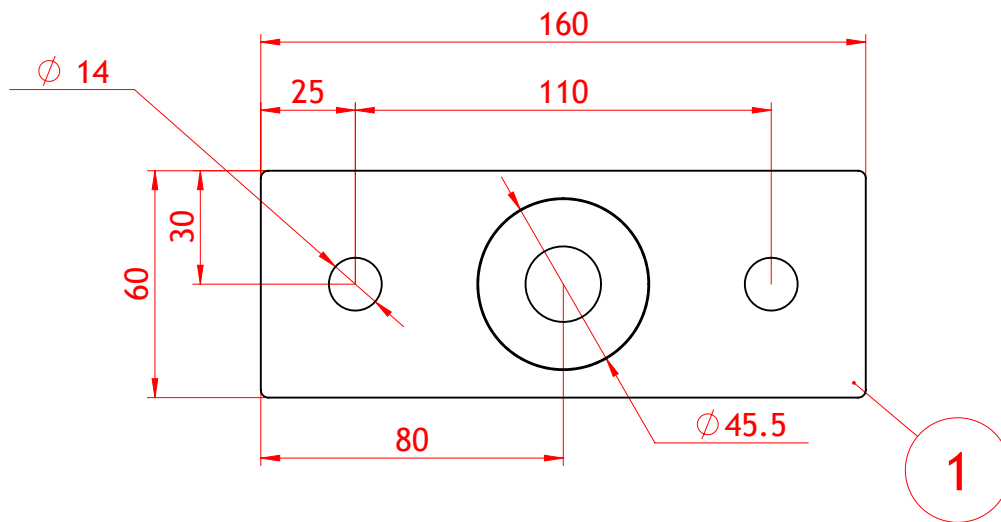

**Electrolitisch verzinken**

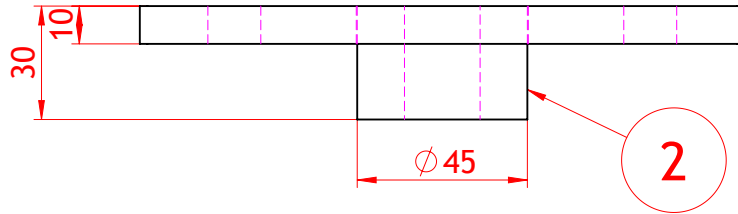
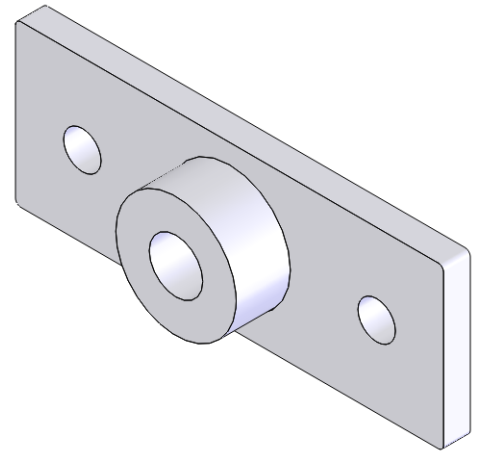

Pos	Aant	Code	Benaming	L	Br.	Extra Tekst
1	1	MAWGWPL050X10	WGW PLAT 50 X 10	160		
2	1	BEMOTR20X4R	RONDMOER-TRAPEZIUM-STAAI TR 20X4 RECHTS	30		

<input type="radio"/> STAAL	Revisie	Datum	Veranderd door	Revisie omschrijving		
		4/12/2015	RvG	Start		
<input type="radio"/> RVS	Proj.nr:	Klant:		Aantal:		
<input type="radio"/> RVS Tegenlassen	Benaming			Goedkeurdatum:	4/12/2015	
<input type="radio"/> RVS Sanitair	Rondsel hoogteverstelling schoonmaaksealstation			Nagekeken door:	RvG	
<input type="radio"/> Electrolytisch Polijsten	 Hoge Mauw 740 2370 Arendonk België Tel: 014-67 23 32 Fax: 014-67 17 60			Datum:	04-12-2015 06:28:46	
<input type="radio"/> Uitw. Volledig Aflassen				Tekenaar:	JEROEN DHONDT	
<input type="radio"/> Uitw. Hechtlassen				Schaal:	Gewicht:	
				1:5	896.34	
				Tekeningsnummer:		Formaat
				27520447		A4

Algemene Tolerantie	0 - 120	120 - 1000	> 1000	Hoek Tolerantie ± 0.5°	Third angle
	± 0.3	± 0.5	± 1		